

Instructions for use

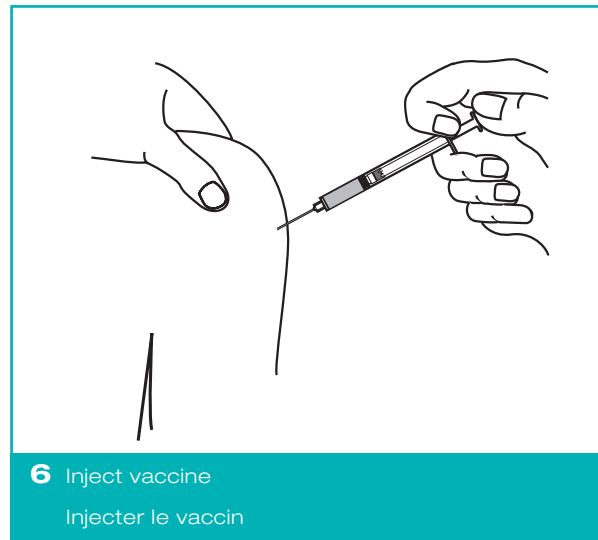

Mode d'emploi

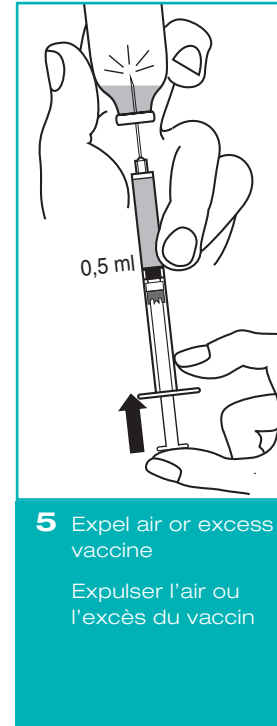
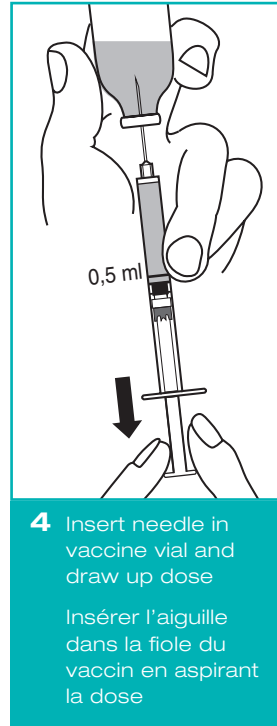
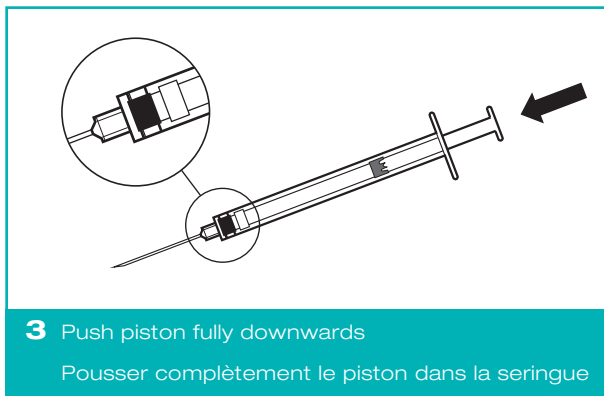
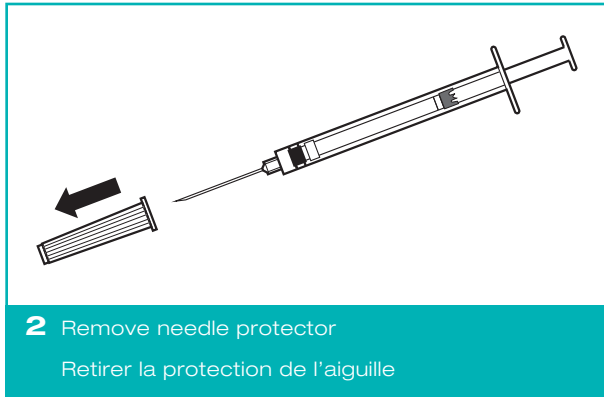
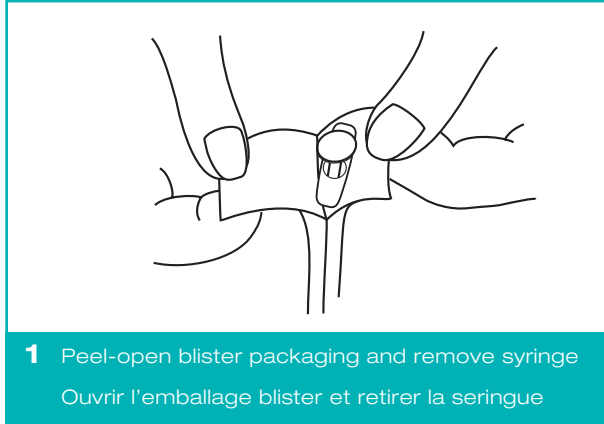
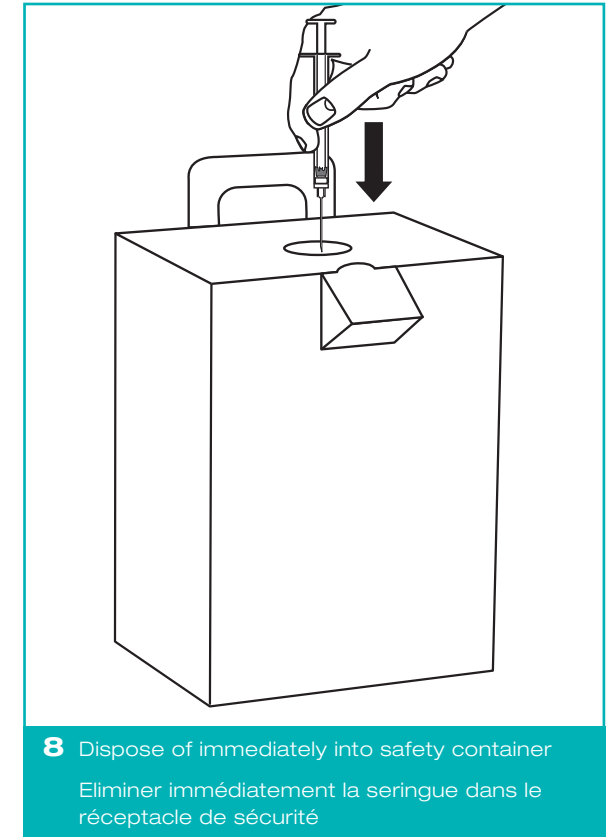
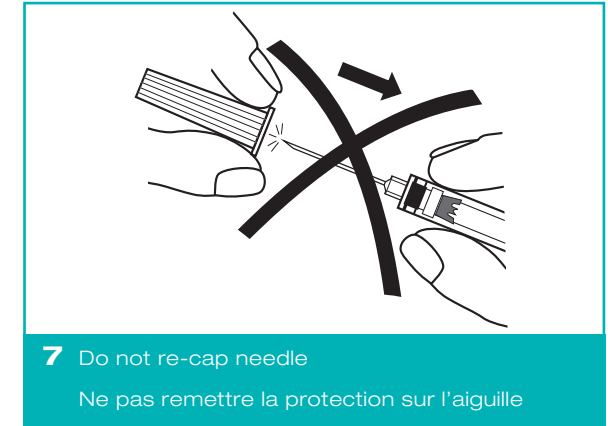

Features and benefits

- AD-Syringes are the equipment of choice for vaccination
- Unique locking mechanism
- Integrated needle reduces vaccine waste
- Terumo's lancet point technology minimizes discomfort
- Ultra-clear barrel for easy recognition of air bubbles or impurities
- Smooth plunger movement with latex-free gasket
- Compact design cuts costs
- Sterile blister pack provides tamperproof evidence
- Terumo® AD-Syringes™ comply with WHO/V&B E8/DS.1 specifications and MDD/93/42/EEC – CE 0197

Caractéristiques et avantages

- La seringue autobloquante est le matériel d'injection le plus approprié pour les vaccinations
- Système de blocage unique
- L'aiguille incorporée permet d'éviter tout gaspillage de vaccin
- La technologie de la pointe «lancet» de Terumo augmente le confort du patient
- La transparence de la seringue assure une parfaite visualisation des bulles d'air ou des impuretés
- Aisance de mobilité du piston dans le corps de la seringue grâce au joint sans latex
- Coûts minimes grâce à une conception compacte de la seringue
- Emballage blister inviolable et stérile
- Les Seringues™-AD TERUMO® sont conformes aux spécifications WHO/V&B E8/DS.1 et MDD/93/42/EEC – CE 0197

Code N° N° de code	Colour code Code couleur	Size Taille	Gauge Gauge	Needle length Longueur de l'aiguille
AD-05I2325	Blue / Bleu	0,5 ml	23G (OD 0.6 mm)	25 mm (1")
AD-05I2525	Orange	0,5 ml	25G (OD 0.5 mm)	25 mm (1")
AD-05I2516	Orange	0,5 ml	25G (OD 0.5 mm)	16 mm (5/8")

Unit box / Boîte 100 pcs

Shipping carton / Carton 1800 pcs

We keep life flowing

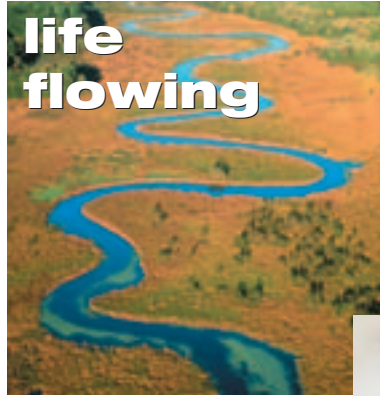

Every day, as healthcare professionals, you are working to ensure life and to contribute to the well-being of your patients. Every day, **Terumo Europe** provides you with the clinical systems, means and solutions to keep life flowing.



 **TERUMO®**

TERUMO EUROPE N.V.
Researchpark Zone 2 Haasrode
Interleuvenlaan 40
B-3001 Leuven
BELGIUM
Tel. +32/16.38.12.11
Fax +32/16.40.02.49

®: Registered Trademark
Published by Terumo Europe N.V.

**TERUMO EUROPE N.V.
BENELUX SALES DIVISION**
Interleuvenlaan 40
B-3001 Leuven
BELGIUM
Tel. +32/16.39.25.80
Fax +32/16.39.25.99
THE NETHERLANDS
Tel. +0800/022.03.96
Fax +0800/022.04.14

www.terumo.com
www.terumo-europe.com

Hospital Systems



Terumo® AD-Syringes™

Auto-disable syringes
for immunization



Contributing
to safer injection
practices

We keep life flowing
 **TERUMO®**